



Unicondylar Sled Prosthesis

with MITUS[®] Instrument Set



Presented by:



CE 0123

Waldemar Link GmbH & Co. KG

Barkhausenweg 10 · 22339 Hamburg, Germany

P.O. Box 63 05 52 · 22315 Hamburg, Germany

Tel.: +49 40 53995-0 · Fax: +49 40 5386929

E-mail: info@linkhh.de · www.linkorthopaedics.com

LINK[®] Unicondylar Sled Prosthesis with MITUS[®] Instrument Set

System Description

- 02 LINK[®] Unicondylar Sled Prosthesis
- 03 Femoral Components and Tibial Plateaus
- 03 PorEx[®] Surface Modification (TiNbN =Titanium Niobium Nitride)
- 03 Indications/Contraindications
- 04 Rünow – Minimally Invasive Surgical Technique

Implants

- 05 Femoral Components
- 05 Tibial Plateaus

Instruments

- 06 MITUS[®] – Instrument Set for Minimally Invasive Technique of Unicondylar Sled
- 10 Additional Instruments
- 11 Tibial Saw Guide

- 12 Important Information for X-ray investigation
- 13 Accessories: X-ray Templates, further Literature

- 14 Index

Important Information regarding the use of our implants

■ LINK® Unicondylar Sled Prosthesis



The successful design of LINK's Unicondylar Sled Prosthesis which was originated in 1969 has remained unchanged since its last modification in 1981. This extraordinary time period and the outstanding long-term clinical results have been reported in a number of publications*.

Further advantages:

- high joint mobility
- short recovery period

The design of the femoral component preserves bone substance and permits femoral resurfacing. This treatment is therefore available as a fall-back option.

The instruments and the surgical technique are regularly optimised to ensure ease of use and reliable implantation.

The LINK® Unicondylar Sled Prosthesis is available in four sizes.

*Exemplary: Annual Report, The Swedish Knee Arthroplasty Register, www.knee.nko.se



Femoral Components

The large radii of the femoral surface distributing the contact stress more homogeneously. The globular structure of the concave inner surface of the sled provides optimal bonding between implant and cement. The design incorporates two posts whose shape and alignment aid in positioning the sled. The implant is easy to remove should revision become necessary.



Tibial Plateaus

The tibial plateaus can be used medially as well as laterally owing to their symmetrical shape. The sizing is adapted to the anatomical shape of the head of the tibia. Two designs are available:

- **Type all-polyethylene** (non metal-backed)

This design is available in four heights and four diameters. The structured underside allows a very good interface between implant and bone cement.



- **Type metal-backed**

In this design, the tibial plateaus are available in three heights and three diameters. The globular structure on the underside of the plateau offers optimum bonding between the implant and bone cement.



PorEx® (TiNbN = Titanium Niobium Nitride) Surface modification

The hypoallergenic PorEx® surface modification leads to a ceramic-like surface, which significantly reduces the release of ions and can improve tolerance in patients who are sensitive to metal¹⁾.

This surface is extremely hard and possesses abrasion properties similar to those of ceramics. These qualities and the wetting angle of the surface give it a low friction coefficient when in contact with fluids¹⁾.

¹⁾ Study of the influence of TiNbN-coating on the ion release of CoCrMo-alloys in SBF buffer simulator testing

Please note:

For specified indications/contraindications see catalogue:

739en_MITUS - Minimally Invasive Technique for Unicondylar Sled Prosthesis, Surgical Technique

■ **Rünow Minimally Invasive Surgical Technique**

For implantation of a sled prostheses is it essential to select the correct indication. The concept is based on the fact that in early stages of knee osteoarthritis (OA) the cartilage damage is limited to a single compartment within the knee joint.

The design of the **LINK® Unicondylar Sled Prosthesis** ensures that only minimal bone resection is required when preparing the bone to receive the femoral and tibial components. This preserves high-quality bone, particularly the hard sub-chondral bone, which is important for secure long-term fixation of the implant.

The **Tibial Saw Guide** supports resection according to anatomical conditions and ensures precise, reproducible bone cuts.

The **MITUS® Instrument Set** offers distinct advantages to the surgeon:

- minimal bone resection
- full control over the level of tibial resection
- opportunity to try out different sizes using trial implants
- option to perform the surgery using either conventional or minimally invasive surgical techniques
- medial or lateral use of instruments possible

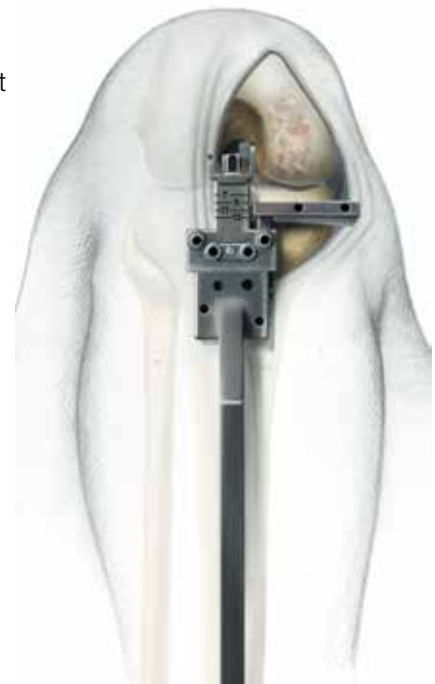

Two different forms of surgical approach can be used

Conventional Approach: through a midline or a medial parapatellar skin incision. The joint cavity is reached via a medial parapatellar incision and splitting of the quadriceps tendon. The patella is everted laterally.

Minimally Invasive Approach: through a short parapatellar skin incision. The capsular incision is also parapatellar allowing access to the joint with minimal disturbance of the extensor mechanism and without dislocating the patella.

The minimally invasive technique reduces complications and can be performed with great precision provided the LINK® instruments are used correctly.

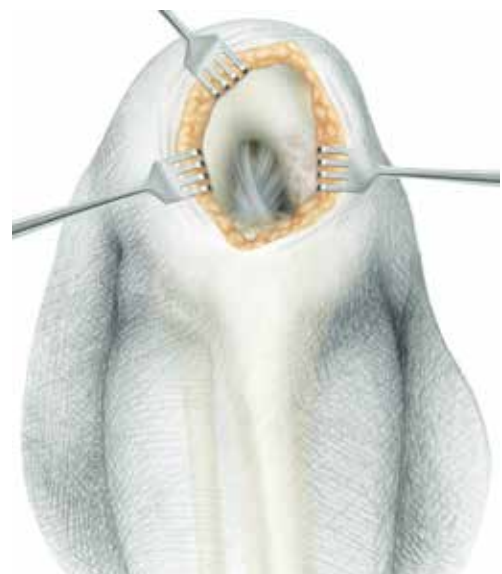

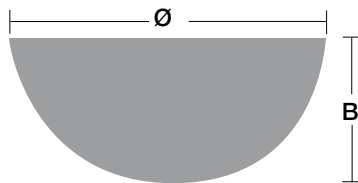

Important information:

Tibial components of 7 mm height offer the advantage of particular bone preservation and allow for a good range of motion. The suitability of these particular components have to be medically indicated. The tibial components of 7 mm height are not suitable for obese or very active patients.

Femoral Components

Material: CoCrMo, CoCrMo/PorEx®*

Item no. CoCrMo	Item no. CoCrMo/PorEx®*	Size	Width (K) mm	Length (T) mm
15-2020/40	15-2220/40	small	16	40
15-2020/46	15-2220/46	medium small	17	46
15-2020/52	15-2220/52	medium	18	52
15-2020/60	15-2220/60	large	20	60

Tibial Plateaus

all-polyethylene (non metal-backed)

Material: UHMWPE

Item no. UHMWPE	Height (H) mm	Ø mm	Width mm
15-2028/01	7	45	22
15-2028/02	9	45	22
15-2028/03	11	45	22
15-2028/04	13	45	22
15-2028/05	7	50	27
15-2028/06	9	50	27
15-2028/07	11	50	27
15-2028/08	13	50	27
15-2028/09	7	55	29
15-2028/10	9	55	29
15-2028/11	11	55	29
15-2028/12	13	55	29
15-2028/13	7	58	31
15-2028/14	9	58	31
15-2028/15	11	58	31
15-2028/16	13	58	31

Tibial Plateaus metal-backed



Material: CoCrMo, CoCrMo/PorEx®*, UHMWPE

Item no. CoCrMo	Item no. CoCrMo/PorEx®*	Height (H) mm	Ø mm	Width (B) mm
15-2030/02	15-2230/02	9	45	22.5
15-2030/03	15-2230/03	11	45	22.5
15-2030/04	15-2230/04	13	45	22.5
15-2030/06	15-2230/06	9	50	25.0
15-2030/07	15-2230/07	11	50	25.0
15-2030/08	15-2230/08	13	50	25.0
15-2030/10	15-2230/10	9	55	27.5
15-2030/11	15-2230/11	11	55	27.5
15-2030/12	15-2230/12	13	55	27.5

* PorEx®: TiNbn = Titanium Niobium Nitride; hypoallergenic coating (gold colour).

■ **MITUS® Instrument Set**

Minimally Invasive Surgical Technique for LINK® Unicondylar Sled Prosthesis

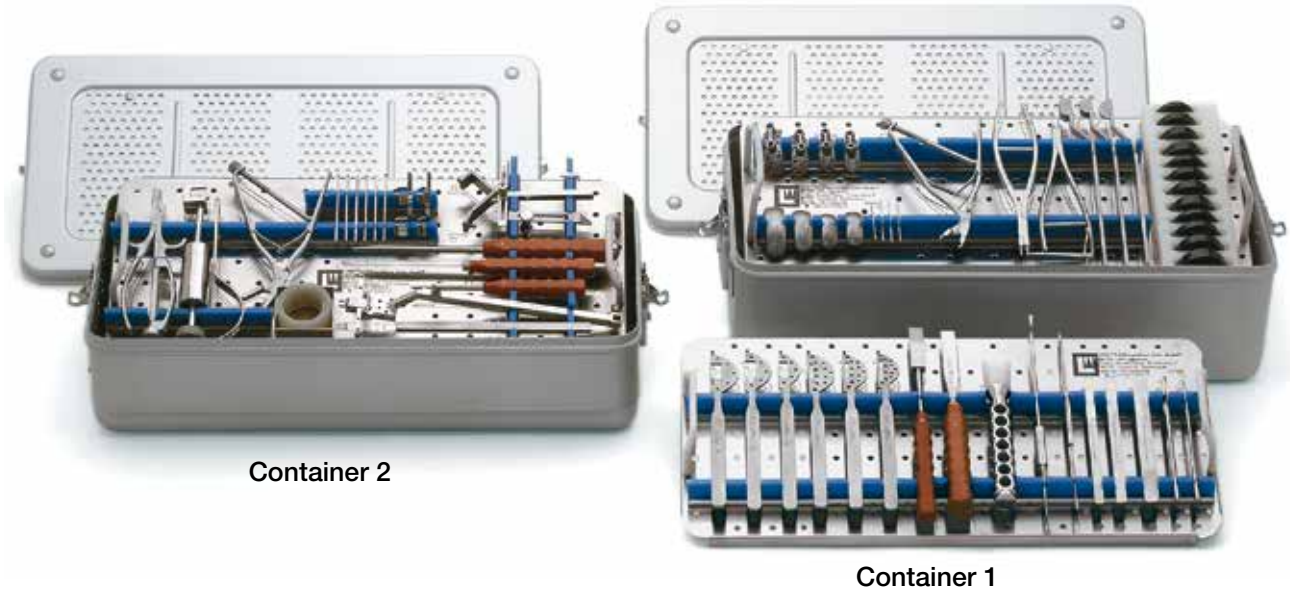

Item no.	Instrument Set, complete (Container 1 and 2)	
15-2201/01	Set, complete in 2 standard containers, on 3 trays with storage inserts, consisting of:	
05-2001/03	N11 Standard Container , empty, stainless steel, 575 x 275 x 100 mm	1 ea.
05-2002/03	N21 Standard Container , empty, stainless steel, 575 x 275 x 130 mm	1 ea.
15-2200/02	Lower Tray (Container 1) , empty, perforated stainless steel, 550 x 265 x 50 mm	1 ea.
15-2200/03	Upper Tray (Container 1) , empty, perforated stainless steel, 550 x 265 x 50 mm	1 ea.
15-2200/01	Tray (Container 2) , empty, perforated stainless steel, 550 x 265 x 50 mm	1 ea.

*Fittings: How to order: 317-649/08B = Hudson fitting

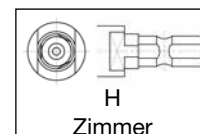
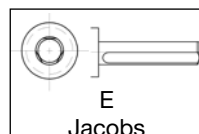
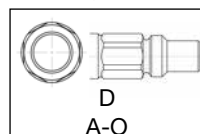
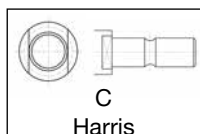
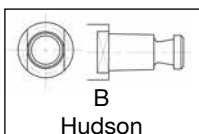

■ Lower Tray, Container 1

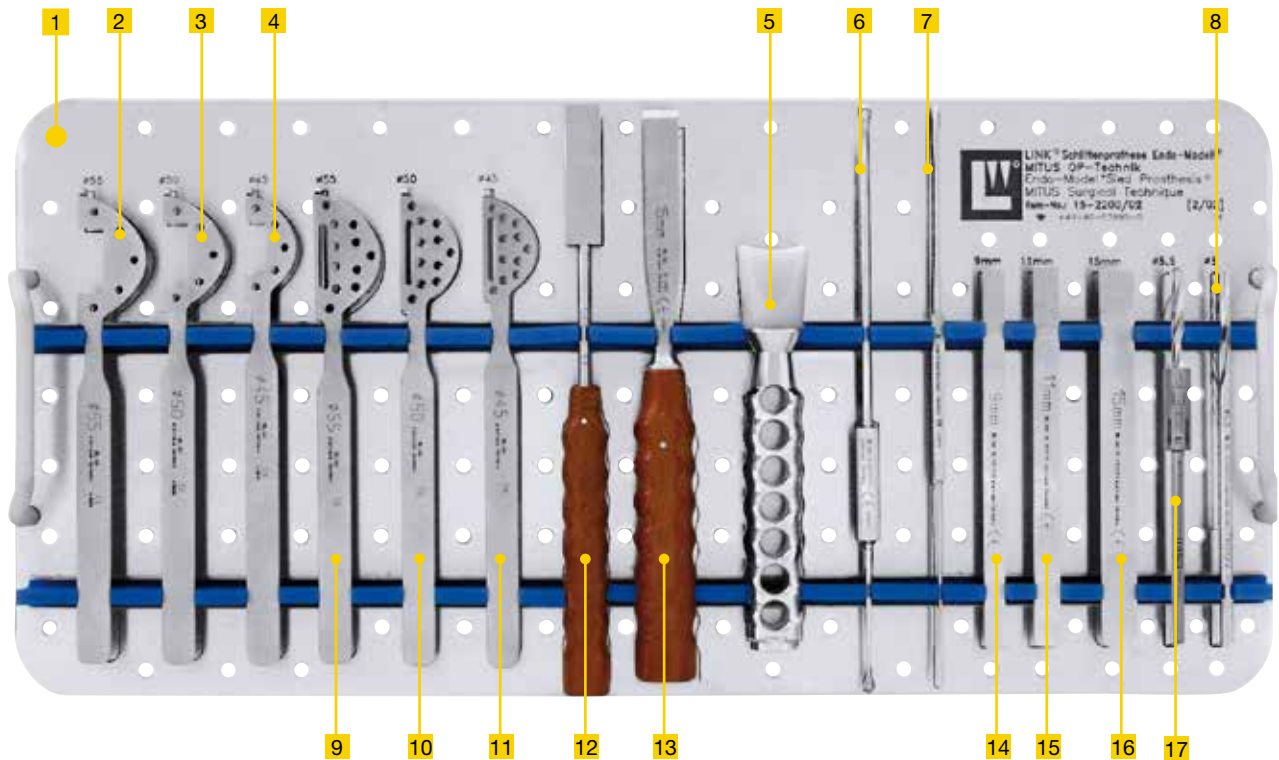

1	15-2200/02	Lower Tray (Container 1), empty, 550 x 265 x 50 mm
Drill and Saw Guide (templates) for tibial plateaus all-polyethylene		
2	15-2201/55	55 mm
3	15-2201/50	50 mm
4	15-2201/45	45 mm
5	15-2040/05	Sled Impactor for sled prosthesis metal-backed, 170 mm
6	15-2201/70	Curette to remove excess cement
7	15-2201/71	Spatula double-end to remove excess cement
8	15-2040/03E*	Twist Drill with stop, Ø 5.5 mm, 160 mm, fittings optional (see page 06)*
Drill and Saw Guides (templates) for tibial plateaus metal-backed		
9	15-2202/55	55 mm
10	15-2202/50	50 mm
11	15-2202/45	45 mm
12	15-2040/06	Plateau Impactor, 250 mm
13	15-2105	Chip Chisel, 15 mm wide, 240 mm
Lambotte Osteotomes		
14	15-2201/16	9 x 160 mm
15	15-2201/17	11 x 160 mm
16	15-2102/03	15 x 160 mm
17	15-2040/02E*	Twist Drill, Ø 3.0 mm, 160 mm, fittings optional (see page 06)*

■ Upper Tray, Container 1

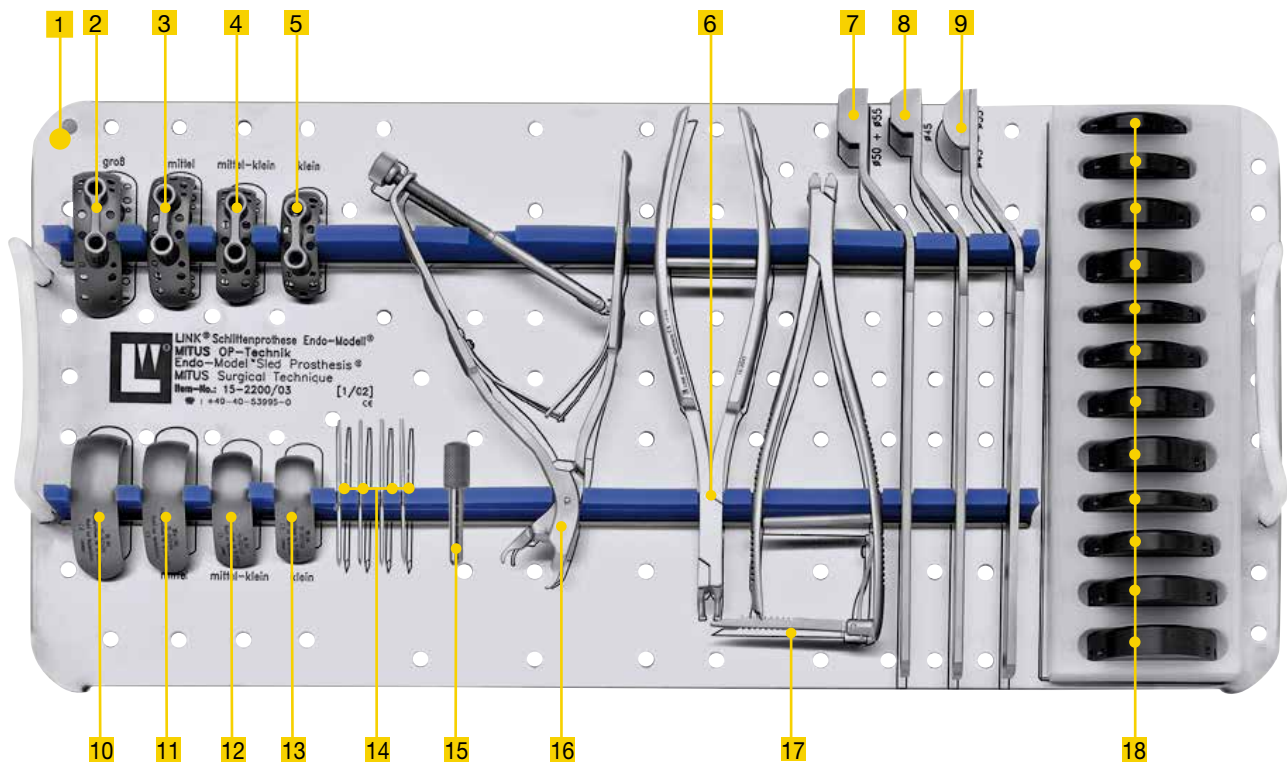

1	15-2200/03	Upper Tray (Container 1) , empty, 550 x 265 x 50 mm
Drill Guides for sled prostheses		
2	15-2201/60	large
3	15-2201/52	medium
4	15-2201/46	medium-small
5	15-2201/40	small
6	15-2042	Inserting Forceps for tibial plateaus all-polyethylene and trial plateaus, 215 mm
Cancellous Bone Compressors for tibial plateaus all-polyethylene		
7	15-2201/14	Ø 50-55 mm
8	15-2201/15	Ø 45 mm
9	15-2201/19	Cancellous Bone Compressor for tibial plateaus metal-backed, Ø 45-55 mm
Trial Sled Prostheses		
10	15-2021/05	large
11	15-2021/04	medium
12	15-2021/03	medium-small
13	15-2021/02	small
14	15-2201/12	Fixation Pins for drill guides, Ø 2 mm, 60 mm
15	15-2201/53	Fixation Pin to stabilise the drill guide, Ø 5.4 mm, 50 mm (4 ea.)
16	15-2201/13	Holding and Inserting Forceps for drill guides
17	15-2040/09	Plateau Holding and Inserting Forceps for tibial plateaus metal-backed
18	15-2040/08	Set of Trial Tibial Plateaus on storage tray, Ø 45, 50, 55 mm, heights: 7, 9, 11, 13 mm (12 ea.)

■ Tray, Container 2

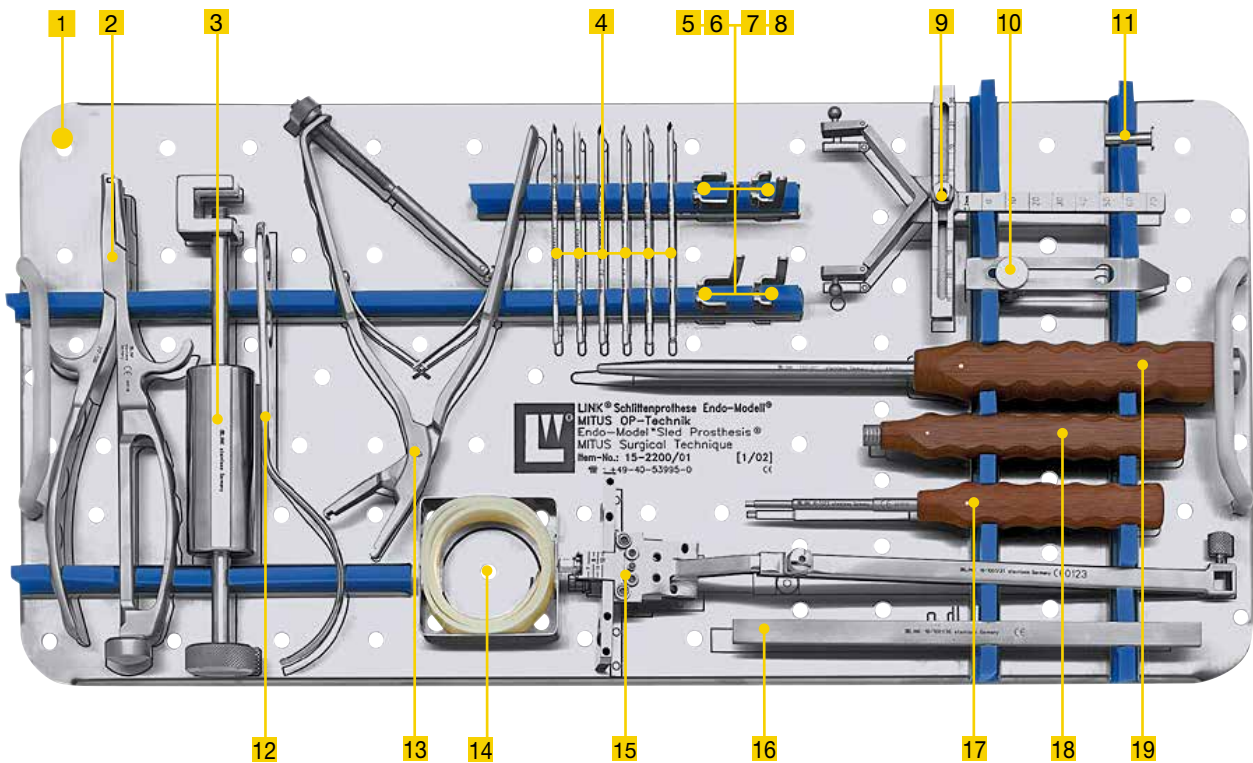

- | | | |
|-----------------------------|------------|---|
| 1 | 15-2200/01 | Tray (Container 2), empty, 550 x 265 x 50 mm |
| 2 | 317-586 | Driver and Extraction Forceps for fixation pins, 210 mm |
| 3 | 15-2201/18 | Extractor for fixation pins, to be used with 317-586 |
| 4 | 317-585/95 | Fixation Pins, Ø 3 mm, 95 mm (6 ea.) |
| Eminentia Saw Guides | | |
| 5 | 15-2201/32 | left, height A |
| 6 | 15-2201/37 | left, height B |
| 7 | 15-2201/33 | right, height A |
| 8 | 15-2201/38 | right, height B |
| 9 | 15-2201/34 | Tibial Alignment Device, extramedullary |
| 10 | 15-2201/35 | Stylus |
| 11 | 15-2201/39 | Spacer Bolt to 15-2201/31 |
| 12 | 15-2201/11 | Retractor |
| 13 | 15-2201/10 | Inserting Forceps for trial sled prostheses |
| 14 | 317-538/01 | Flexible Belt, 495 mm |
| 15 | 15-2201/31 | Tibial Saw Guide Base, adjustable |
| 16 | 15-2201/36 | Alignment Rod, transversal, 200 mm |
| 17 | 10-5373 | Hexal Screwdriver, hex 2.5 mm, 180 mm |
| 18 | 317-648 | Universal Wrench, hex 6.0 mm, 140 mm |
| 19 | 130-611 | Impactor, 280 mm |

■ Additional Instruments

Trial Tibial Plateaus, Ø 58 mm,
suitable for tibial plateaus all-polyethylene
(without metal-backed)

Item no.	Height mm	Width mm
15-2047/13	7	31
15-2047/14	9	31
15-2047/15	11	31
15-2047/16	13	31



15-2048/04

Storage Tray, separate
for trial tibial plateaus, Ø 58 mm

15-2201/58

Drill and Saw Guide (templates)
for tibial plateaus all-polyethylene,
Ø 58 mm



■ Tibial Saw Guide 15-2201/30



317-538/01 Flexible Belt, 495 mm

15-2201/34 Tibial Alignment Device, extramedullary

The tibial saw guide consists of a base with one cutting platform for medial resection and another for lateral resection. The stylus is inserted into a hole on the cutting platform. The spacer bolt is fixed on the opposite side. To protect the intercondylar eminence, eminentia saw guides are available.

The adjustable extramedullary tibial saw guide base determines the correct axial alignment. A transversal alignment rod helps to align the saw guide horizontally. The saw guide is fixed distally using a plastic connector. The saw guide is secured proximally with fixation pins.

15-2201/32 - /38 Eminentia Saw Guide, left and right



15-2201/35 Stylus

15-2201/39 Spacer Bolt

is inserted into the unused opening for fixation of the cutting platform and is secured by tightening fixation screw **A**. The screw is thus prevented from migrating inwards as a result of the vibration during sawing

15-2201/36 Alignment Rod, transversal, 200 mm

Cutting Platform

15-2201/31 Tibial Saw Guide base, adjustable

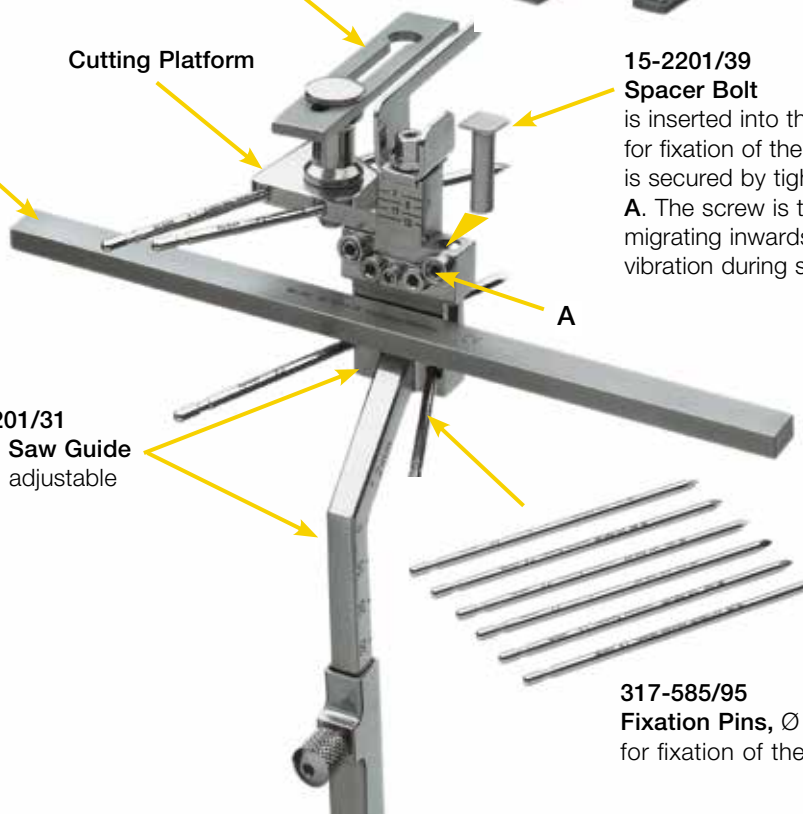

317-585/95 Fixation Pins, Ø 3 mm, 95 mm for fixation of the tibial saw guide

■ Important Information for X-ray Investigations

X-ray investigations

X-ray images can be used to evaluate implant positioning post-operatively. Images taken from certain angles can create the impression that the implant has broken.



Fig. 1: Post-operative X-ray 1

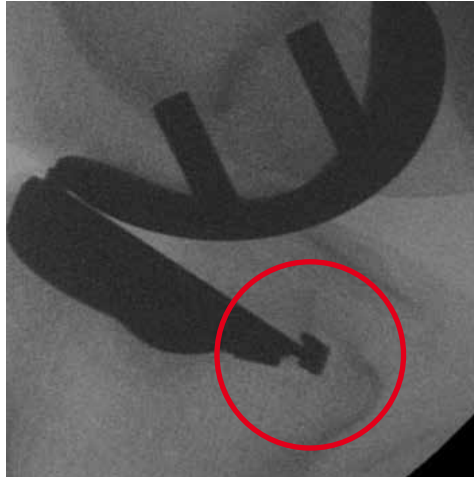

Fig. 2: Post-operative X-ray 2

Note

The LINK® tibial plateau metal-backed is delivered as one piece, i.e. the polyethylene component and the metal component are pre-assembled as a single unit. The manufacture of the components has remained unchanged since today. For secure connection the polyethylene engages with a mechanical coupling device.

These technical specifications can lead X-ray images taken from certain angles to appear distorted, which may give the impression that the tibial plateau is broken. Examples of such distorted images are shown below:



Fig. 3a: Photograph of externally rotated tibia

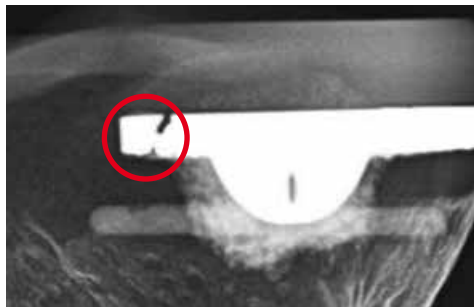

Fig. 3b: X-ray image of figure 3a

As a broken tibial plateau is most unlikely, the diagnosis must be verified with additional X-ray images.

Verification:

Rotation of the tibia ensuring strictly lateral alignment for the follow-up X-ray.



Fig. 4a: Photograph of tibia from a strictly lateral position

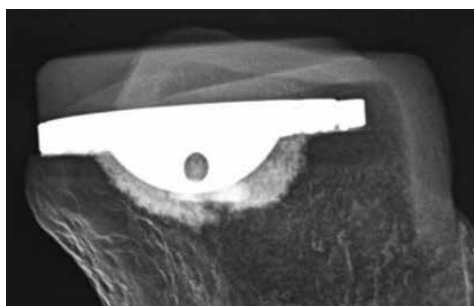
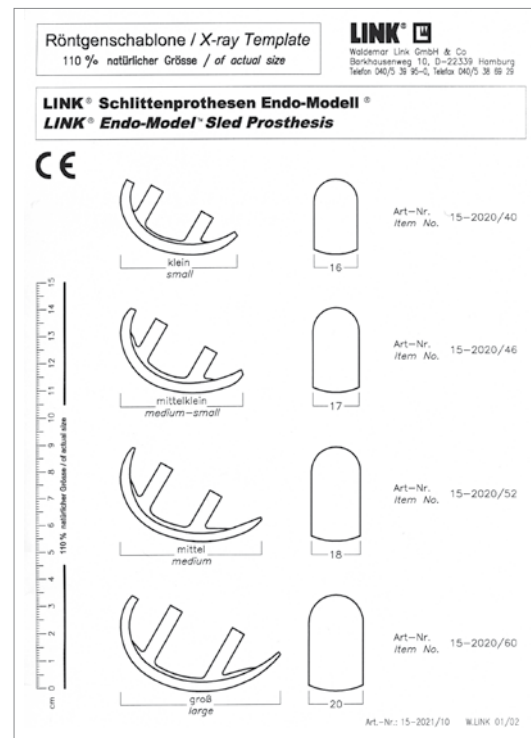

Fig. 4b: X-ray image of figure 4a

■ X-ray Templates

X-ray Templates, 110% actual size, one sheet

Item no.	Application
15-2021/10	for Unicondylar Sled Prosthesis 15-2020/40 to 15-2020/60
15-2021/11	for Tibial Plateaus, metal-backed 15-2030/01 to 15-2030/12
15-2021/13	for Tibial Plateaus, all-polyethylene 15-2028/01 to 15-2028/12



■ Further Literature

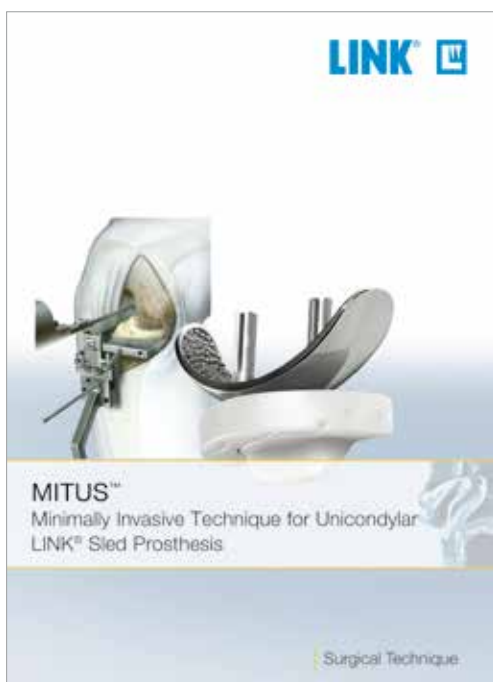

Catalogue:
MITUS® Surgical Technique
available on request.

	Seite		Seite
05-2001/03	06	15-2201/33	09
05-2002/03	06	15-2201/34	09,11
10-5373	09	15-2201/35	09,11
15-2020/40	05	15-2201/36	09,11
15-2020/46	05	15-2201/37	09
15-2020/52	05	15-2201/38	09,11
15-2020/60	05	15-2201/39	09,11
15-2021/02	08	15-2201/40	08
15-2021/03	08	15-2201/45	07
15-2021/04	08	15-2201/46	08
15-2021/05	08	15-2201/50	07
15-2021/10	13	15-2201/52	08
15-2021/11	13	15-2201/53	08
15-2021/13	13	15-2201/55	07
15-2030/02 bis 15-2030/12	05	15-2201/58	10
15-2040/02	07	15-2201/60	08
15-2040/03	07	15-2201/70	07
15-2040/05	07	15-2201/71	07
15-2040/06	07	15-2202/45	07
15-2040/08	08	15-2202/50	07
15-2040/09	08	15-2202/55	07
15-2042	08	15-2220/40	05
15-2047/13	10	15-2220/46	05
15-2047/14	10	15-2220/52	05
15-2047/15	10	15-2220/60	05
15-2047/16	10	15-2228/01 bis 15-2228/16	05
15-2048/04	10	15-2230/02 bis 15-2230/12	05
15-2048/05	10	130-611	09
15-2102/03	07	317-538/01	09,11
15-2105	07	317-585/95	09,11
15-2200/01	06,09	317-586	09
15-2200/02	06,07	317-648	09
15-2200/03	06,08		
15-2201/01	06		
15-2201/10	09		
15-2201/11	09		
15-2201/12	08		
15-2201/13	08		
15-2201/14	08		
15-2201/15	08		
15-2201/16	07		
15-2201/17	07		
15-2201/18	09		
15-2201/19	08		
15-2201/30	11		
15-2201/31	09,11		
15-2201/32	09,11		

Please note the following regarding the use of our implants:

1. Choosing the right implant is very important.

The size and shape of the human bone determine the size and shape of the implant and also limit the load capacity. Implants are not designed to withstand unlimited physical stress. Demands should not exceed normal functional loads.

2. Correct handling of the implant is very important.

Under no circumstances should the shape of a finished implant be altered, as this shortens its life span. Our implants must not be combined with implants from other manufacturers.

The instruments indicated in the Surgical Technique must be used to ensure safe implantation of the components.

3. Implants must not be reused.

Implants are supplied sterile and are intended for single use only. Used implants must not be reused.

4. After-treatment is also very important.

The patient must be informed of the limitations of the implant. The load capacity of an implant cannot compare with that of healthy bone!

5. Unless otherwise indicated, implants are supplied in sterile packaging.

Note the following conditions for storage of packaged implants:

- Avoid extreme or sudden changes in temperature.
- Sterile implants in their original, intact protective packaging may be stored in permanent buildings up until the "Use by" date indicated on the packaging.
- They must not be exposed to frost, dampness or direct sunlight, or mechanical damage.
- Implants may be stored in their original packaging for up to 5 years after the date of manufacture. The "Use by" date is indicated on the product label.
- Do not use an implant if the packaging is damaged.

6. Traceability is important.

Please use the documentation stickers provided to ensure traceability.

7. Further information on the material composition is available on request from the manufacturer.

Follow the instructions for use!

Waldemar Link GmbH & Co. KG, Hamburg

All content in this catalog, including text, pictures and data, is protected by law. Every instance of use, whether in part or in whole and which is not permitted by law, is subject to our prior consent. In particular, this applies to the reproduction, editing, translation, publishing, saving, processing, or passing on of content stored in databases or other electronic media and systems, in any manner or form. The information in the catalogs is solely intended to describe the products and does not constitute a guarantee.

The Surgical Technique described has been written to the best of our knowledge and belief, but it does not relieve the surgeon of his/her responsibility to duly consider the particularities of each individual case.

Unless otherwise indicated, all instruments are made of surgical stainless steel.



Waldemar Link GmbH & Co. KG

Barkhausenweg 10 · 22339 Hamburg, Germany
P.O. Box 63 05 52 · 22315 Hamburg, Germany
Tel.: +49 40 53995-0 · Fax: +49 40 5386929
E-mail: info@linkhh.de · www.linkorthopaedics.com

LINK[®]

